



# CUSTOMIZED COIL REQUEST FORM



Name: ..... Date: .....

## 1 Fill the Dimensions

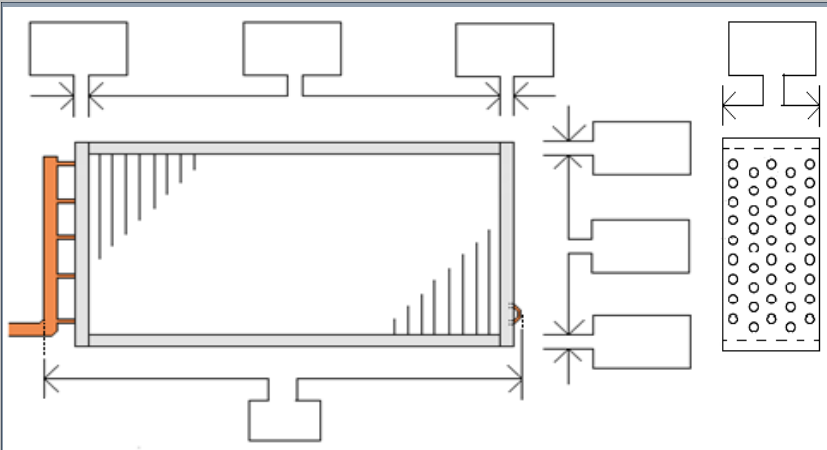

## 2 Choose Tube Size

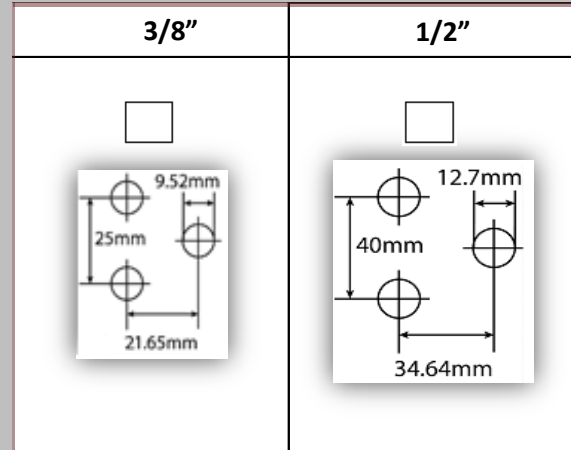

## 3 Choose Technical Sketch

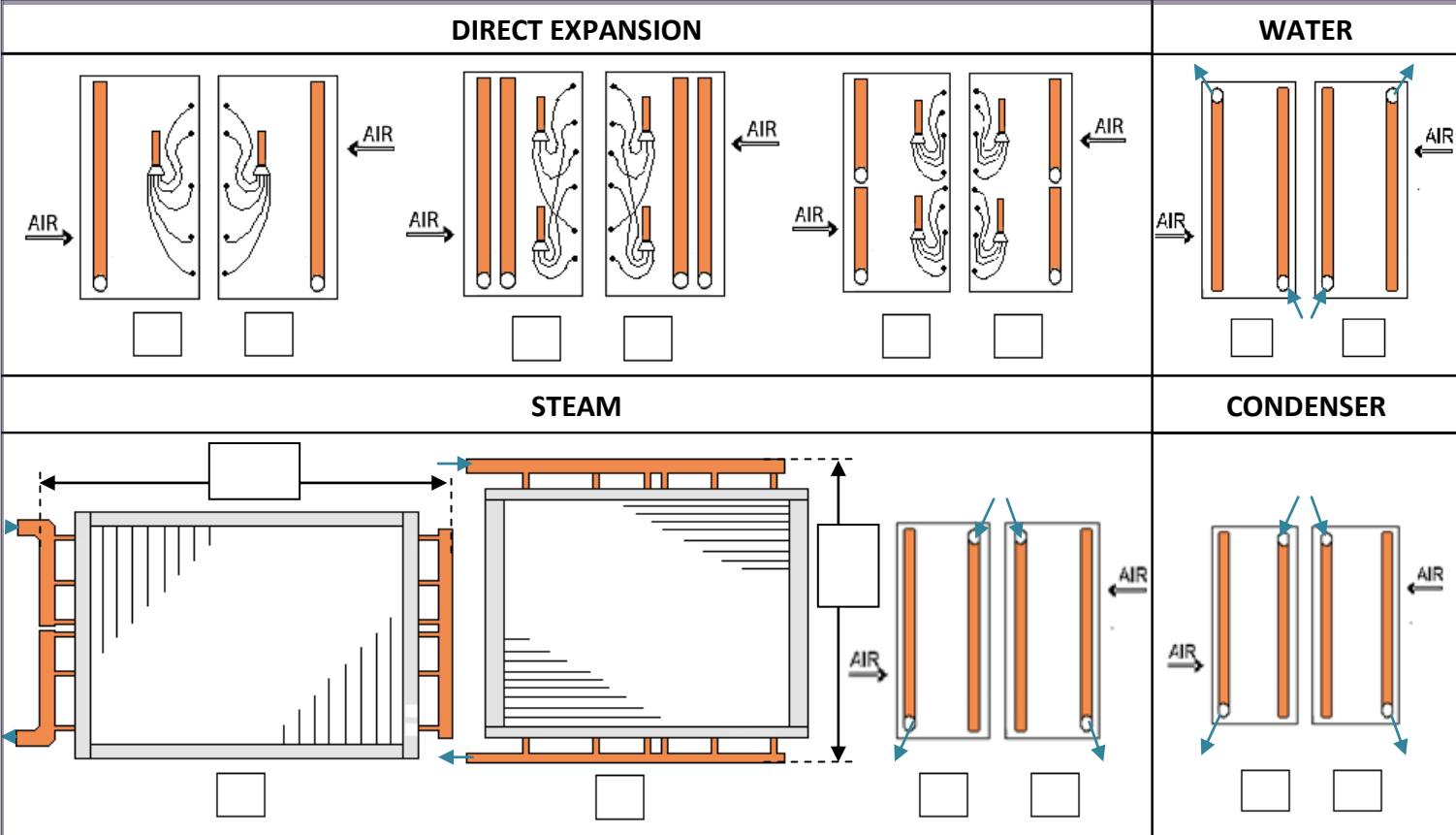

## 4 Fill Technical Details

Fin Spacing:	3/8"	1,8mm <input type="checkbox"/>	2,1mm <input type="checkbox"/>	2,3mm <input type="checkbox"/>	2,8mm <input type="checkbox"/>	.....mm <input type="checkbox"/>
	1/2"	3,0mm <input type="checkbox"/>	4,1mm <input type="checkbox"/>	6,4mm <input type="checkbox"/>	10mm <input type="checkbox"/>	.....mm <input type="checkbox"/>
Manifold diameter				PIECES		
Number of tubes Horizontal						
Number of tubes Vertical						
Number of circuits						

Comments:

### TEPSA LTD

**DESIGN AND MANUFACTURE OF HEAT EXCHANGERS**  
 18 Kyprou & Archimidous, Tavros 17778 Athens – Greece  
 Tel: (0030) 210 4819013 – (0030) 210 4825149  
 Fax: (0030) 210 4829973  
 E-mail: tepsa@otenet.gr  
 URL: [www.tepsa.gr](http://www.tepsa.gr)